

Classic Update Series

AS MENTIONED ON THE "STOP" WARNING PAGE CONTAINED IN THIS KIT BOX, THIS AAW KIT DOES NOT SUPPORT THE USE OF A FACTORY AMMETER, ALTERNATOR WARNING LAMP, OR FACTORY CIRCUITED DASH TACHOMETER. AS A REPLACEMENT FOR THE AMMETER OR ALTERNATOR LAMP, WE SUGGEST THE USE OF A VOLTMETER TO MONITOR THE CHARGING SYSTEM INSTEAD. IF YOU ARE USING THE FACTORY IN DASH TACH, IT MUST BE UPGRADED TO A NEWER STYLE INTERNAL ELECTRONIC MOVEMENT. REFER TO SHEETS 2 OR 3 FOR CONNECTING TO A STOCK INSTRUMENT CLUSTER WITH A FACTORY "PRINTED CIRCUIT BOARD". BE SURE TO INSTALL THE WIRES AS SHOWN FOR "GAUGES WITHOUT A TACH" OR "GAUGES WITH AN UPDATED FACTORY TACH". IF YOU ARE USING AN AFTERMARKET GAUGE PANEL, REFER TO PAGE 4. TERMINAL KIT 92965220 HAS BEEN PROVIDED FOR YOU TO CONNECT THIS CLUSTER KIT TO YOUR AFTERMARKET GAUGE PANEL.

CONNECTOR F - Plug this connector into the mating connector on the dash harness (bag G) and connect wires as follows:

Wire Color	Function	Stock circuit board connection
PINK	12v Ignition	Route this wire to the circuit board and cut to length. Install terminal A (or larger terminal C if used on a factory tach dash, loose end to tach power), and plug into connector B in the location shown on sheets 2 or 3 depending on your application. DK
GREEN	Temperature Sender	Route this wire to the circuit board and cut to length. Install terminal A, and plug into connector B in the location shown on sheets 2 or 3 depending on your application.
DK BLUE	Oil Pressure Sender	Route this wire to the circuit board and cut to length. Install terminal A, and plug into connector B in the location shown on sheets 2 or 3 depending on your application.
TAN	Fuel Sender	Route this wire to the circuit board and cut to length. Install terminal A, and plug into connector B in the location shown on sheets 2 or 3 depending on your application.
BLACK	Ground	Route this wire to the circuit board and cut to length. Install terminal A, and plug into connector B in the location shown on sheets 2 or 3 depending on your application.

CONNECTOR G - Plug this connector into the mating connector on the dash harness (bag G) and connect wires as follows:

Wire Color	Function	Stock circuit board connection
GREY	Instrument Lamps	Route this wire to the circuit board and cut to length. Install terminal A, and plug into connector B in the location shown on sheets 2 or 3 depending on your application. NOTE: A car with factory gauges and a tach (page 3) requires 2 separate lamp feeds to the printed circuitboard. This can be done either one of two ways: 1. Via an in-line splice using two of the single terminals A. 2. Route the gray wire to the circuitboard, cut it to length, double it with the cut off portion and crimp on terminal C, then route the loose end of the grey wire to the circuit board and crimp on terminal A. Either way is correct and will work. See page 3 of this instruction set for these two different examples.
DK BLUE	Right Turn Lamp	Route this wire to the circuit board and cut to length. Install terminal A, and plug into connector B in the location shown on sheets 2 or 3 depending on your application.
LT BLUE	Left Turn Lamp	Route this wire to the circuit board and cut to length. Install terminal A, and plug into connector B in the location shown on sheets 2 or 3 depending on your application.
TAN	Brake Lamp	Route this wire to the circuit board and cut to length. Install terminal A, and plug into connector B in the location shown on sheets 2 or 3 depending on your application.
LT GREEN	Hi Beam Lamp	Route this wire to the circuit board and cut to length. Install terminal A, and plug into connector B in the location shown on sheets 2 or 3 depending on your application.

LOOSE WIRES

PURPLE	VSS signal	Not used in stock configuration. Used ONLY with an electronic speedometer. This wire will plug into connector F, maintaining color continuity with the purple wire on the mating dash connector. Connect the other end to the speedometer 'sender' terminal following the manufacturer's instructions.
YELLOW	VSS ground	Not used in stock configuration. Used ONLY with an electronic speedometer. This wire will plug into connector F, maintaining color continuity with the yellow wire on the mating dash connector. Connect the other end with the ring terminal to a good chassis ground following the manufacturer's instructions.
WHITE	Tachometer	Used ONLY with a tachometer. Plug this loose wire into connector F maintaining color continuity with the white "TACH" wire on the mating dash connector. Route the other end of this wire to the tach, cut to length, and install onto tach pulse location as shown on sheet 3.
BROWN	ACC Voltage	Used with a stock cluster. Plug this loose wire into connector F, maintaining color continuity with the brown wire with the white stripe on the mating dash connector. Route the other end of this wire to the circuit board and cut to length. Install terminal A, and plug into connector B in the location shown on sheets 2 or 3. This is the low voltage feed for the constant voltage unit.
BROWN	Park Lamp	Used ONLY with Dakota Digital dash panels. Plug this wire into connector G, maintaining color continuity with the brown "PARK LAMP" wire on the mating dash connector. Connect the other end to the gauge manufacturer's panel - 'DIM' location. This will dim the panel lights when headlights are turned on.

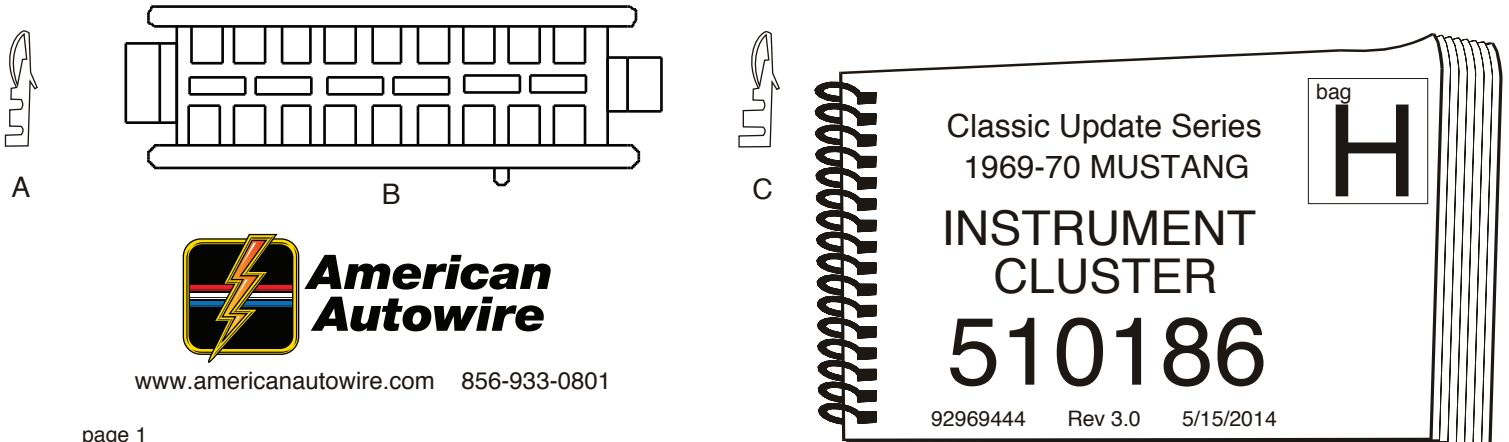

www.americanautowire.com 856-933-0801

USE THIS SHEET TO CONNECT TO AN ORIGINAL 1969-70 MUSTANG FACTORY INSTRUMENT CLUSTER WITH A CIRCUIT BOARD CONNECTION **WITHOUT TACH**

CIRCUIT BOARD CONNECTOR
WITH GAUGES & NO TACH

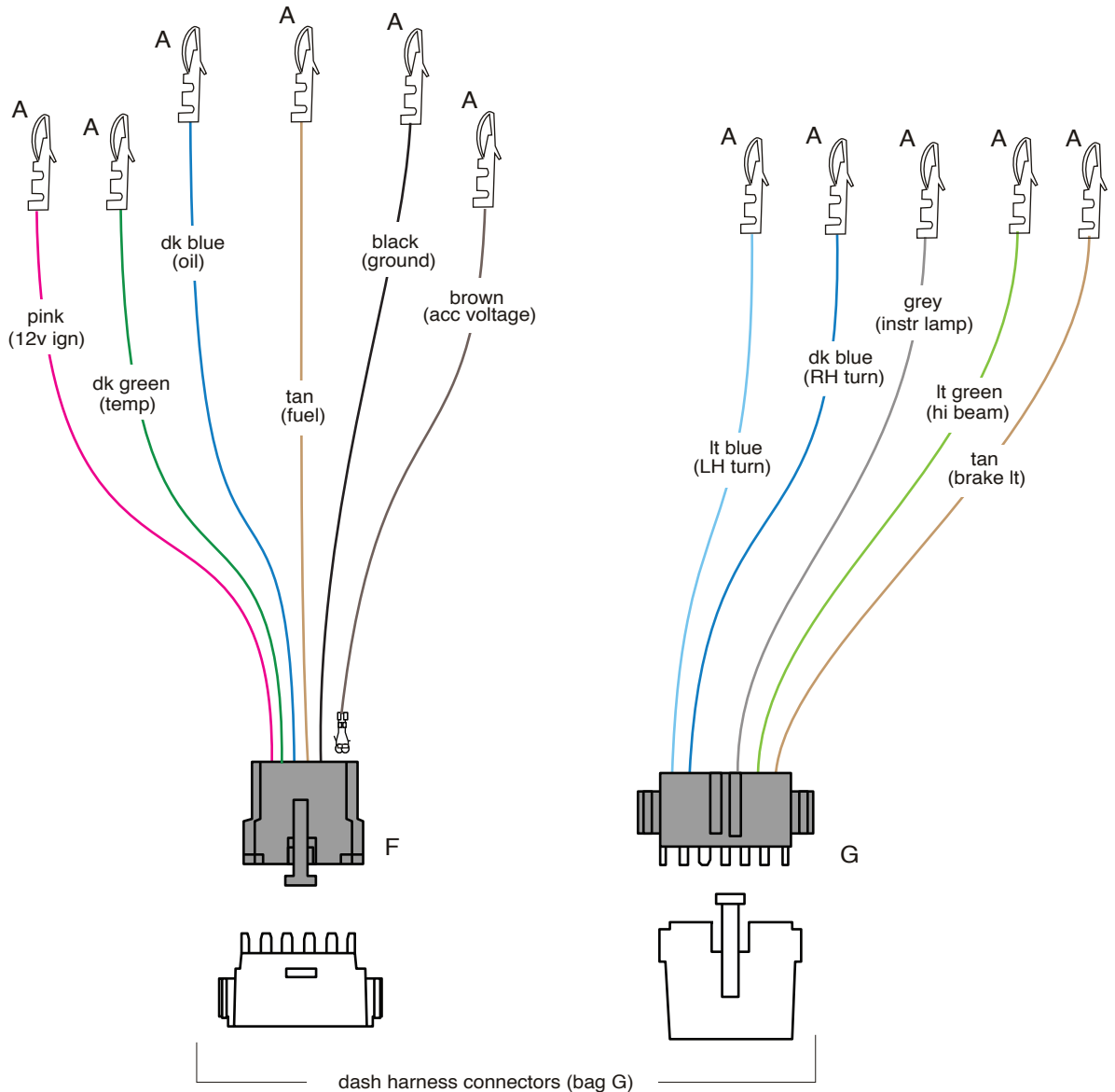
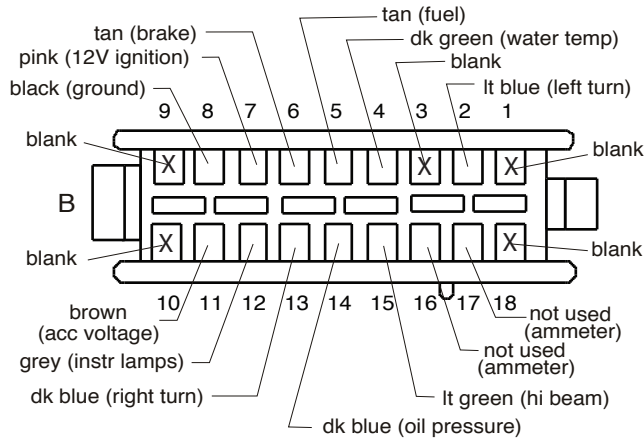

USE THIS SHEET TO CONNECT TO AN ORIGINAL 1969-70 MUSTANG FACTORY INSTRUMENT CLUSTER WITH A CIRCUIT BOARD CONNECTION AND **UPDATED TACH**

SHOWN IS AN INTERNALLY **UPDATED** FACTORY TACH

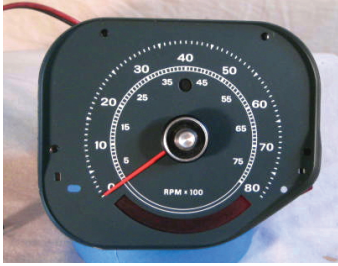

CIRCUIT BOARD CONNECTOR
WITH GAUGES & **UPDATED TACH**

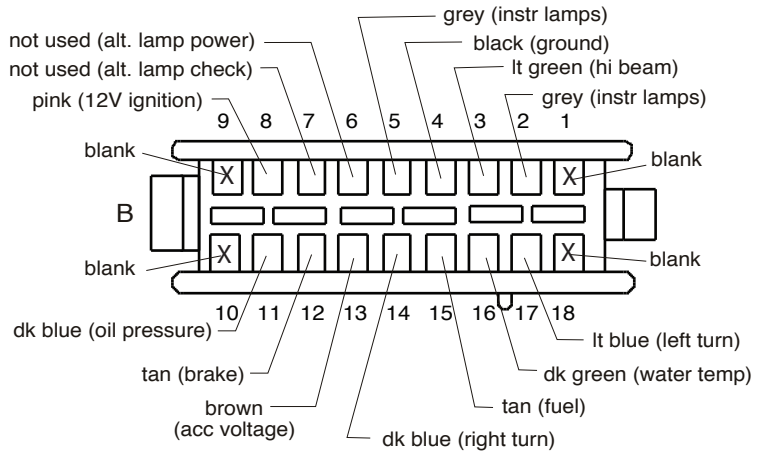

Classic Update Series

tach "out" to negative coil
ignition 12v power into tach

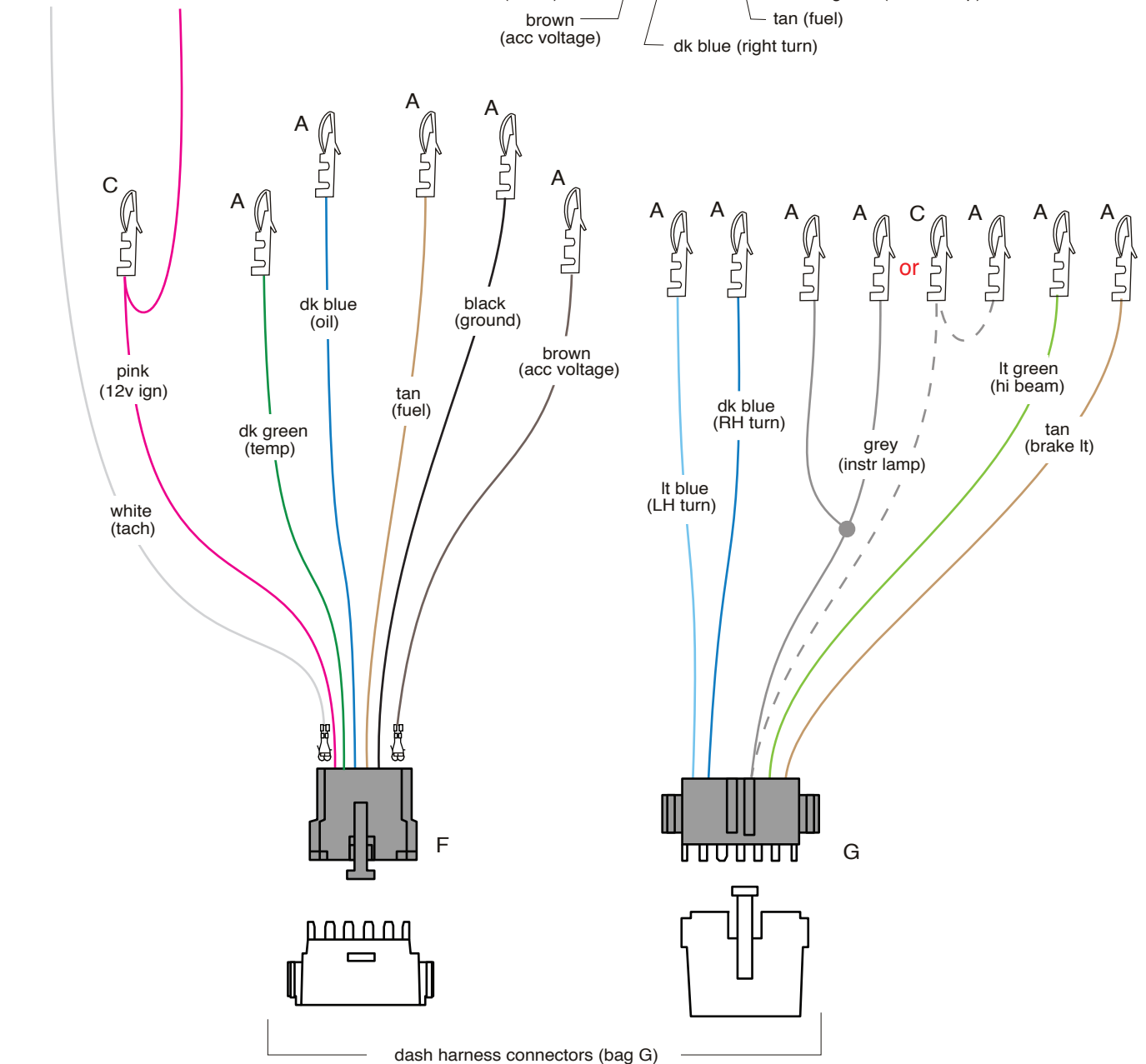

TYPICAL BLADE TYPE GAUGE CONNECTIONS

Classic Update Series

